

Terminal Strip — TLB series — TLB-200HW

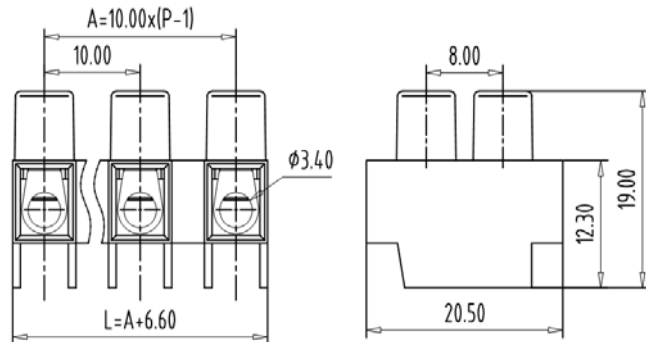
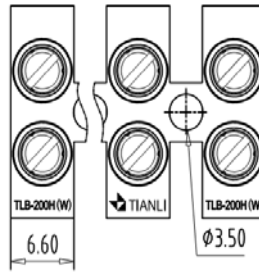

■ 图示(Pic. shown) : TLB-200HW-12P-T01S

General:	Terminal Strip Rated : 450V,32A , 4mm ²
	10.00mm pitch , 02-12 Pole
	Wire-to-Wire Connection
	Screw clamp unit: M3, 0.5Nm Max

认证 (Approval) :



	UL standard			IEC standard		
	B	C	D	IEC过电压别/污染等级(IEC overvoltage category /pollution degree)		
UL应用组别(UL Application group)	UL Application group			IEC过电压别/污染等级(IEC overvoltage category /pollution degree)		
IEC过电压别/污染等级(IEC overvoltage category /pollution degree)				III / 3	III / 2	II / 2
额定电压(Rated voltage)	300V	300V	300V	--	450V	--
额定电流(Rated current)	30A	30A	10A	--	32A	--
额定连接容量(Rated connection capacity)	22-10AWG Sol&Str			0.75-4mm ²		
绝缘材料(Insulation Material)	PA66 UL94 V-2					
电流承载部件材料和镀层(Material & Plating of Current carrier)	Copper alloy , Ni plated					
接线弹片材料(Material of Clamp spring)	--					
绝缘电阻(Insulation Resistance)	500M Ω or more at DC500V					
耐电压(1分钟)(Withstanding Voltage/1Min)	2500V					
额定冲击电压(Rated surge voltage)	--					
接线螺丝(Wire clamp unit Screw) , 最大扭矩(torque Max.)	M3 , 0.5Nm Max					
固定螺丝(Mounting Screw) , 扭矩(torque)	--					
剥线长度(Wire stripping length)	5-6.0mm					
使用温度(Operating temperature)	-40°C up to +80°C					
焊接方式(Soldering recommend)	--					

■ 订购方式(How to order)

